

Quick Installation Guide FOR LC:

1. With aid of supplied mounting template cut mounting holes into the enclosure. Ensure Control unit and Relief Valve are diagonally opposing.
2. Fix MiniPurge Control Unit to enclosure.
3. Fix Relief Valve to enclosure.
4. Pipe between MiniPurge Control Unit & Relief Valve.
5. Connect Output option, /IS or /PO as required, refer to manual.
6. Connect isolated air supply to MiniPurge Control Unit
7. Ensure enclosure door is closed and sealed from leaks.
8. Turn on air supply.
9. Slowly increase Leakage Compensation Valve until Alarm Indicator turns from RED to GREEN.
10. Turn Purge Control Valve to ON and ensure Purge Indicator turns from BLACK to YELLOW.
11. After Purge time has been completed turn Purge Control Valve OFF.
12. Power can now be applied to enclosure.
13. All queries refer to manual for assistance in the first instance.

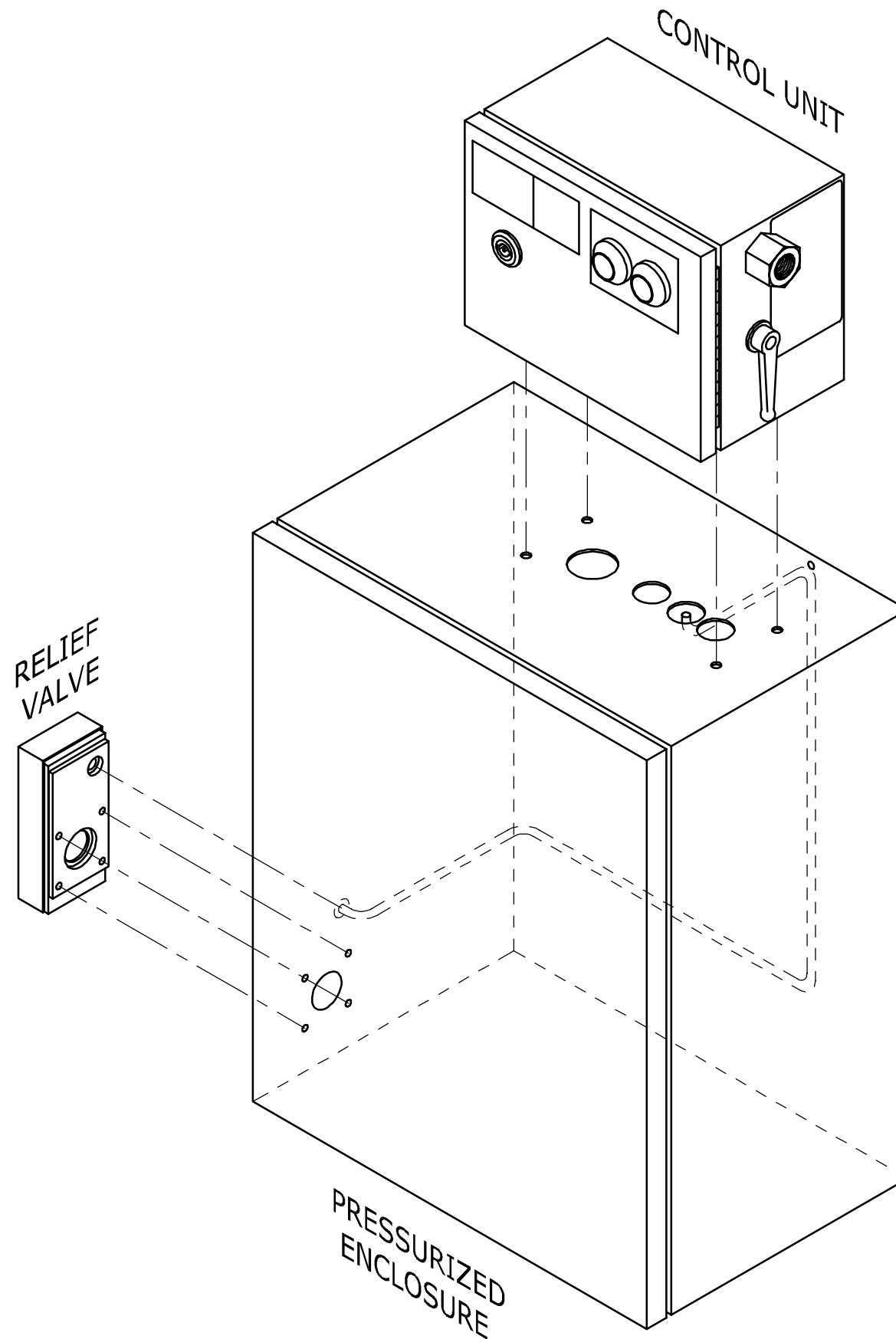

APP'D		ISSUE:	1				
		MOD. No:	DRAWN				
CHK'D		DATE:	09/01/04				
		APPROVED:					
DR'WN	CDM	DRAWING STATUS:					

MATERIAL	
FINISH	

Expo Technologies Limited SURREY KT7 0RH UNITED KINGDOM	
TITLE ZLC/ss QUICK INSTALLATION GUIDE	
JOB No:	CUSTOMER:

SCALE	NTS
DRAWING No.	XBR-8TD0-013
SHEET No.	1 OF 1

